

Cod. 3010.2551 3010.2606	Tipo - Type VA15 - BP70/LL - 51A Aspirante - Suction VA15 - BP70/LL - 51S Soffiante - Blowing	Diametro ventola - Fan diameter 255 mm
--	---	--

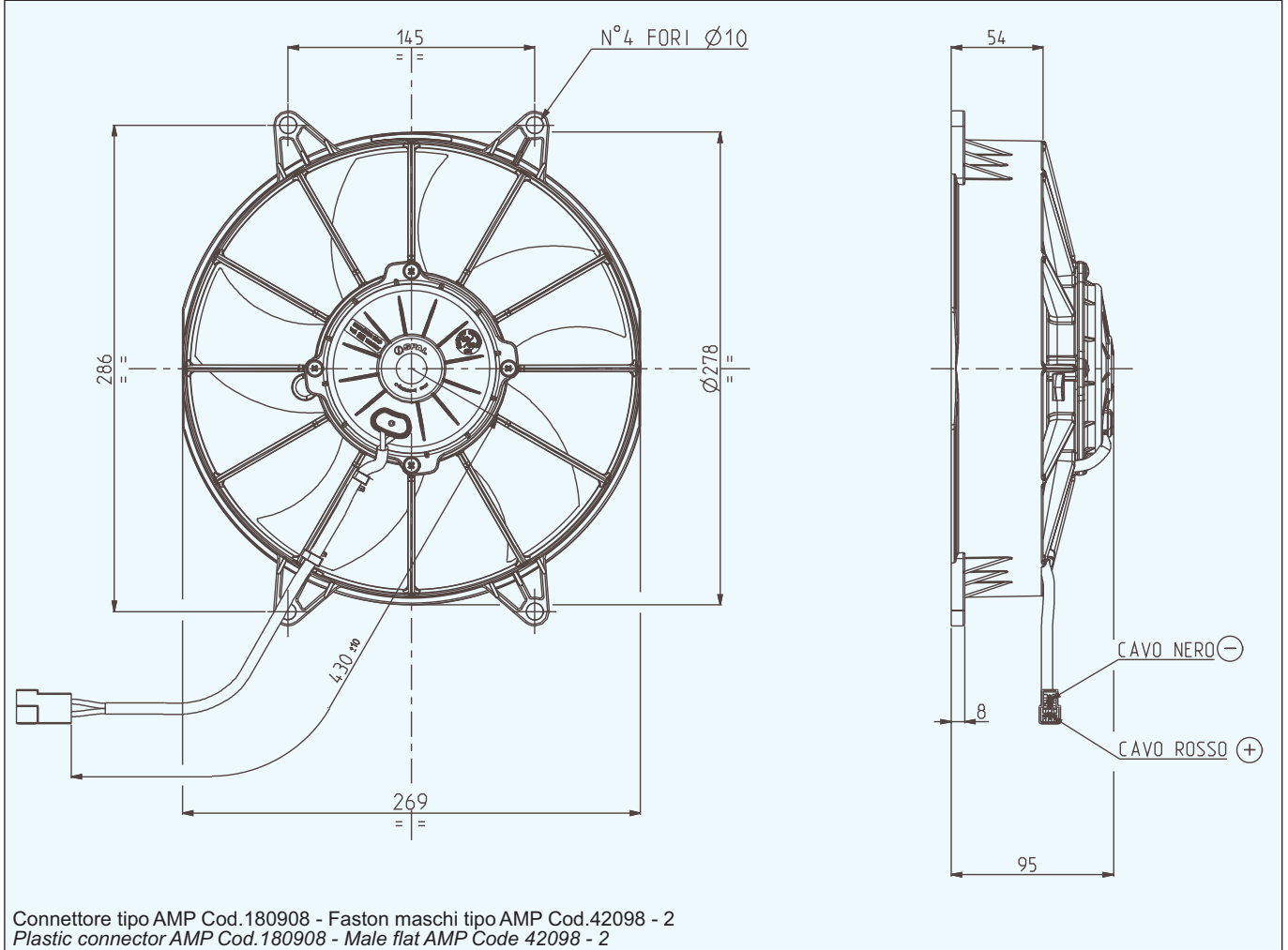

* Peso 2,240 kg. circa * *Weight 2,240 Kg. approx.*

* Motore chiuso, IP 68 * *Waterproof motor, IP 68*

* Lunga durata * *Long life*

* A richiesta (per applicazioni OEM) disponibile anche in versione VLL. * *Available also in VLL version for OEM applications only.*

* Elettroventilatore a bassa rumorosità * *Low noise fan*

Tensione di prova 26 V cc - Test voltage 26 V DC

Pressione statica Static pressure mm H ₂ O	ASPIRANTE - SUCTION		SOFFIANTE - BLOWING	
	Portata Airflow m ³ /h	Corrente assorbita Current input A	Portata Airflow m ³ /h	Corrente assorbita Current input A
0	2050	6,8	1960	6,5
5	1890	7,3	1770	7,0
10	1720	7,6	1590	7,4
15	1470	7,7	1300	7,7
20	950	7,5	1050	7,8
25	720	7,8	750	8,0
30	560	7,8	400	7,8
35	450	8,2	150	8,1
40	330	8,5	0	8,2
45	150	8,6	-	-
50	100	9,0	-	-
55	0	9,0	-	-

Static pressure: 1 mm H₂O = 0,04 in. H₂O
Airflow: 1 m³/h = 0,59 cfm