

Cod. 3010.2082	Tipo - Type VA33 - AP71/LL - 65A Aspirante - Suction	Diametro ventola - Fan diameter 385 mm
---------------------------------	---	---

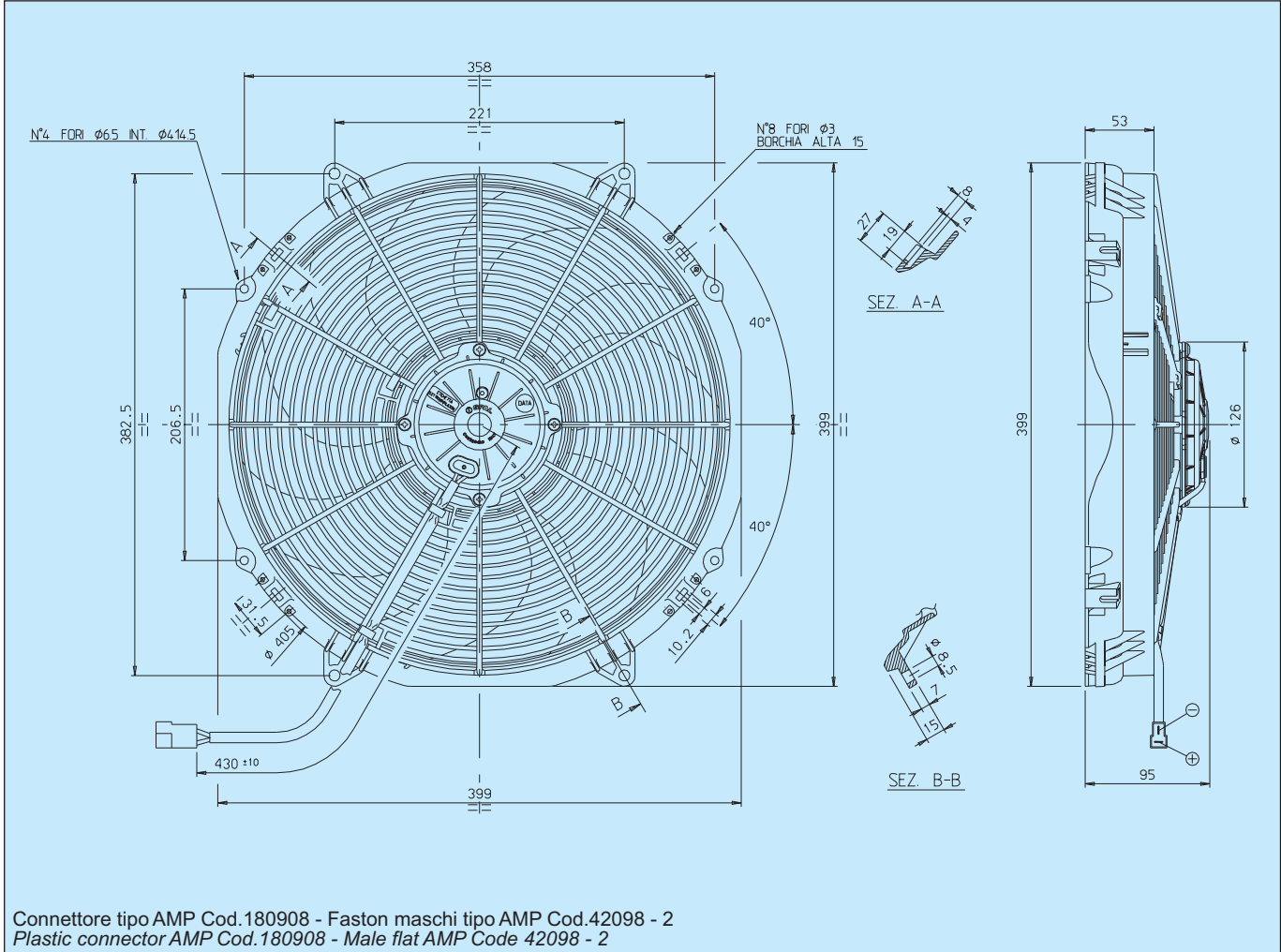

[Empty box for notes]

- * Peso 2,840 kg. circa * Weight 2,840 Kg. approx.
- * Motore chiuso, IP 68 * Waterproof motor, IP 68
- * Lunga durata * Long life
- * A richiesta (per applicazioni OEM) disponibile anche in versione VLL. * Available also in VLL version for OEM applications only.
- * Accessori disponibili: tutti i kit di fissaggio. * Available accessories: all the fixing kits.
- * Elettroventilatore a bassa rumorosità * Low noise fan

[Empty box for notes]

Tensione di prova 13 V cc - Test voltage 13 V DC

Pressione statica Static pressure mm H ₂ O	Portata Airflow m ³ /h	Corrente assorbita Current input A
0	3180	20,7
5	2850	21,8
10	2490	21,0
12,5	2310	21,1
15	1970	20,8
17,5	1480	19,7
20	900	19,6
25	550	19,4
30	0	20,3

Static pressure: 1 mm H₂O = 0,04 in. H₂O
Airflow: 1 m³/h = 0,59 cfm